



METPAR SOLID PHENOLIC TOILET ENCLOSURES

Type F/C-FP/CH - Floor-To-Ceiling

MATERIALS: Solid phenolic with melamine surface both sides produced with resin impregnated materials compressed at pressures exceeding 1000 p.s.i. at 256 degrees Fahrenheit resulting in a solid, dense, water resistant product. All edges to be black.

THICKNESS: Doors..... Finished thickness to $\frac{3}{4}$ " (19.05mm) at 58" (1473) high
Panels..... Finished thickness to $\frac{1}{2}$ " (12.7mm) at 58" (1473) high
Pilasters..... Finished thickness to $\frac{3}{4}$ " (19.05mm) various heights

CONSTRUCTION:

Doors and Panels:

Doors and panels are manufactured from solid phenolic materials. Laminating to a core material is not an acceptable alternative. All edges are beveled and polished. Phenolic is Class-B fire rated based on E-84 Tunnel testing; NFPA No. 255 and U.L. No. 723.

Pilasters:

Pilasters are manufactured from solid phenolic materials. Laminating to a core material is not an acceptable alternative. All edges are beveled and polished. Phenolic is Class-B fire rated based on E-84 Tunnel testing; NFPA No. 255 and U.L. No. 723. Pilasters are to be secured to floor with type 304 stainless steel mounting clips. Pilasters are to be secured to structural ceiling members (furnished by others) using $\frac{3}{8}$ " (9.52) diameter bolts and pilaster leveling nuts. Lock washers used with all nuts to prevent loosening by vibration. Tension nuts will be used to apply equal and opposite pressure to all points of the mounting system. Zinc plated, $\frac{3}{8}$ " (9.52) diameter studs, lock washers and nuts will be provided. All pilasters will have a 3" (76.2) high #4 finish stainless steel plinth and have straight, flat sides to match pilaster profile.

BRACKETS:

Wall and pilaster brackets are 13 gauge stainless steel. All connections use 1-ear or 2-ear stirrup brackets with a minimum of two (2) per connection.

DOOR HARDWARE:

Each compartment will be complete with all stainless steel surface mounted hardware including; door hinges, latch, stop and keeper, coat hook, as well as all the necessary fittings and fastenings for a complete installation. Fasteners are stainless steel through bolts with tamper-proof Torx-Pin heads. Door hinges to be surface mounted and attached with thru-bolts to doors and pilasters. Hinge material to be 12 gauge 304 stainless steel with bearing angles of 16 gauge 304 stainless to be electrically welded to full length of both leaves of the top and bottom hinge assemblies to prevent door sag. Fully adjustable door positioning cam and pintle to be made from nylon with a stainless steel pin encased in nylon. Pin must be held in position with snap ring design. Remaining door hardware (e.g. latch, S&K, etc.) is cast stainless steel.

OPTIONAL FEATURES:

Maximum privacy with a rabbeted edge on the strike side of each door to mate with a coinciding rabbeted edge on each pilaster, coupled with a full height MultiCam hinge to eliminate any gaps. Aluminum curtain track, glides and curtains. Phenolic dressing seats. Full height stainless steel angles and U-brackets. Class-A rated solid phenolic material.



95 State Street, Westbury, New York USA 11590
Tel: 516-333-2600 ~ Fax: 516-333-2618
www.Metpar.com ~ Sales@Metpar.com

Get a 3-part detailed
industry format spec
sheet for 10-21-00
Toilet Partitions?



DIMENSIONS IN () = MILLIMETERS

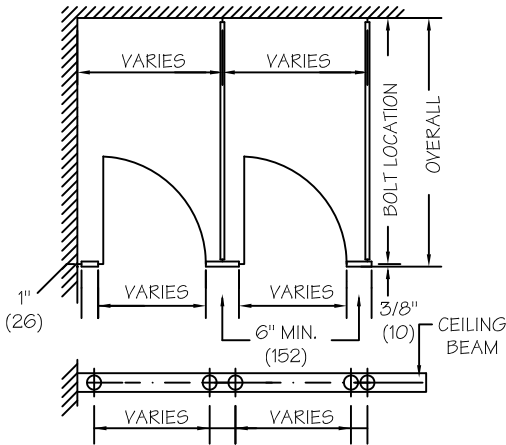

FLOOR PLAN

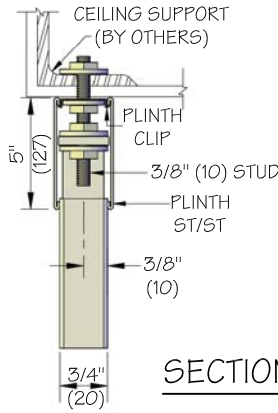

SECTION-A-1

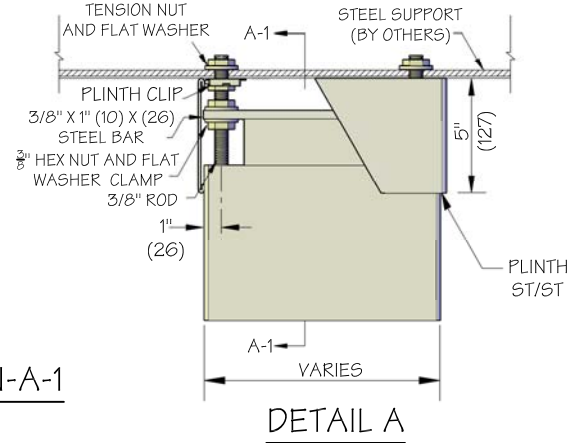

DETAIL A

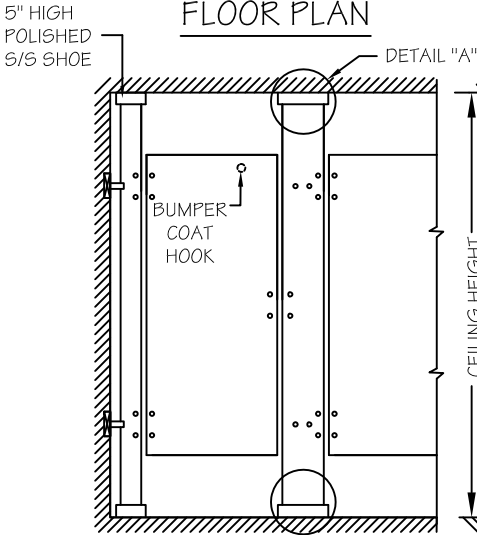

FRONT ELEVATION

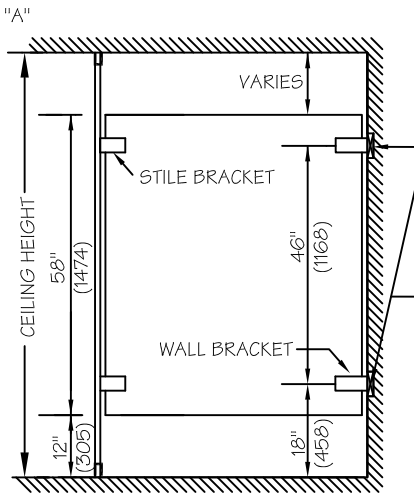

SIDE ELEVATION

Blocking (by others) shown for standard CPZ stirrup brackets. for full height or any other bracket, consult with Metpar distributors for blocking information and locations.

NOTES: This drawing is a standard detail intended to show general construction and specification information. see shop drawings for actual job layout and specific job conditions which supercede any conflicting information on this sheet.

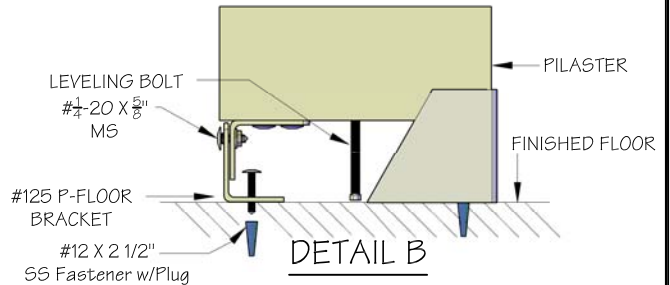

DETAIL B

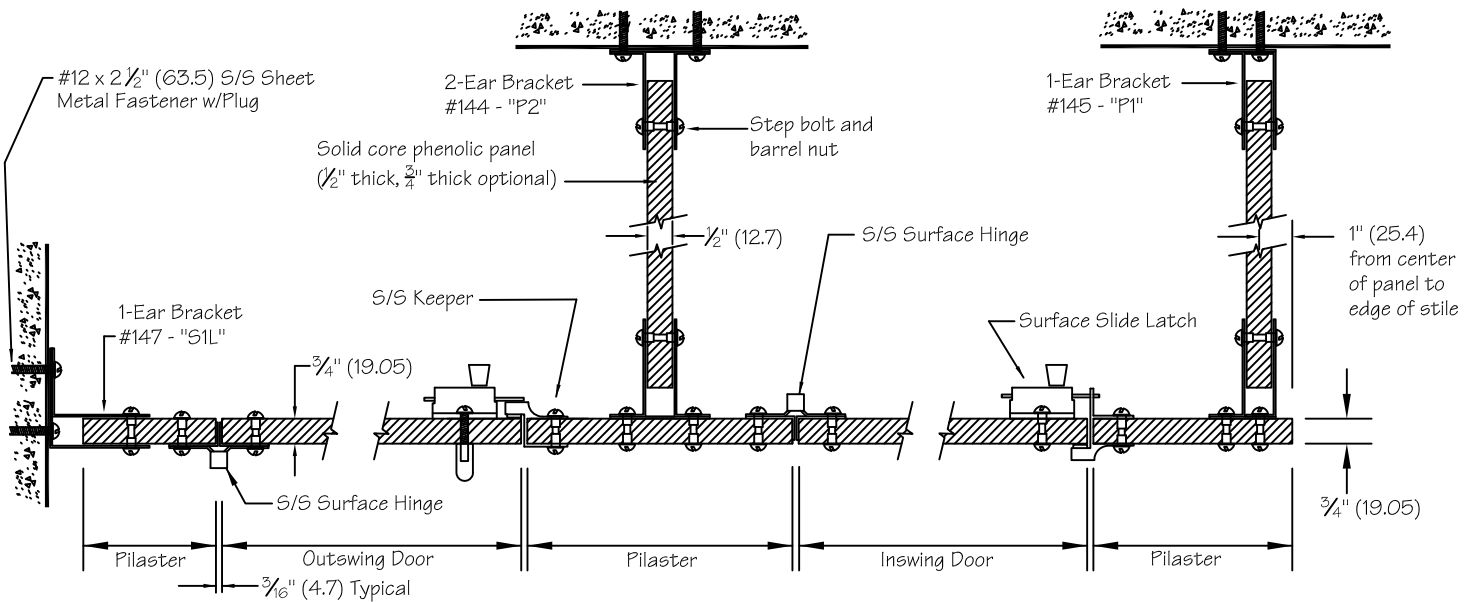

METPAR CORP

95 State Street, Westbury, NY 11590
 Tel: 516-333-2600 Fax: 516-333-2618
 www.Metpar.com ~ Sales@Metpar.com

SOLID PHENOLIC

SPECIAL DETAIL FP BOTTOM CH TOP
 FLOOR TO CEILING

FCFPCHPH.DWG

09/07/2017